

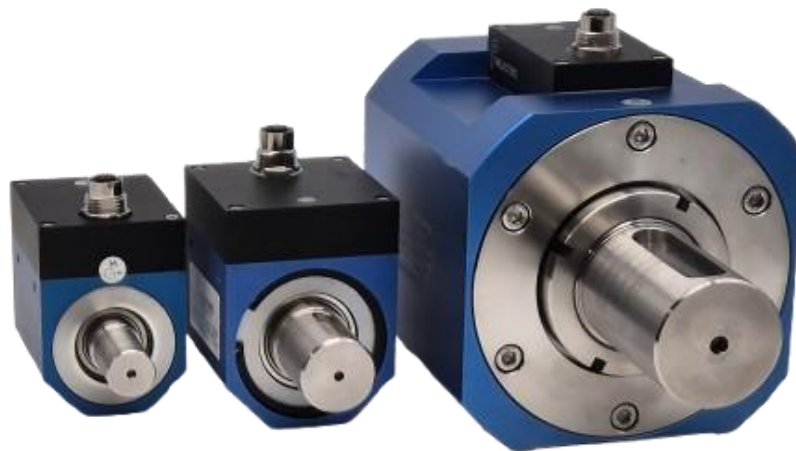

Datasheet – MES Torque Sensor

Range 0,1 Nm to 5000 Nm



Copyright © Melectric Systems GmbH® torque sensor MES instruction manual and data sheet.
These operating instructions are the property of Melectric Systems GmbH®,

D-82064 Strasslach

Unauthorized duplication, even in part, is not permitted.

Status: August 2023

Table of content

1.	Instruction of use.....	3
2.	Customer Service Address.....	3
3.	Warranty.....	3
4.	Scope of delivery	3
5.	Safety.....	4
6.	Intended use.....	4
7.	Recalibration and duration of use	4
8.	Structural changes.....	4
9.	Assembly and Disassembly.....	4
10.	Disposal:	4
11.	Key Sensor Parameter	5
12.	Typical Values.....	5
13.	Dimension	6
14.	Accessories.....	9
15.	Adapter clutches	9
	Order Codes.....	10

1. Instruction of use

Dear customers,

Thank you for choosing our sensor products. You have chosen a high quality and extremely precise torque measuring system. These instructions for use contain everything for you and the assembly, operating and maintenance personnel necessary information so that you can use your measuring system under the intended conditions of use.

It contains important information that ensures a functional and safe installation and operation. For these reasons, the operating instructions must always be at hand at the place of use of the torque measuring system are available.

We reserve the right to make changes in the course of product improvements. We're trying to do that maintain compatibility with previous versions. All information without guarantee subject to technical changes.

2. Customer Service Address

Melectric Systems GmbH

Endlhauser Straße 7

82064 Straßlach

Tel: [+49 8170 9969055](tel:+4981709969055)

Email: info@melectric-systems.de

Web: www.melectric-systems.de

3. Warranty

The warranty is 12 months from the date of delivery from the factory when used as intended, under

Compliance with the maintenance and calibration regulations, as well as the general terms and conditions.

4. Scope of delivery

The torque sensor system consists of a calibrated sensor integrated in the housing as well as an integrated processing unit. Furthermore, a cable will be provided, please only use the provided equipment to run the sensor.

5. Safety

Please note the enclosed sheet on the warning notices

Care must be taken to ensure that the flat surfaces of the shaft are clean when installing the sensor issue.

- When fastening, no force may be exerted on the housing in the axial direction.
- The sensor is not designed as a support bearing.

6. Intended use

The sensor is exclusively designed for measuring torque and/or speed.

The respective load range can be found in the data sheet, it is not allowed to exceed the maximum torque range.

Intended use also includes compliance with the manufacturer's specifications Commissioning, assembly, operating, environmental and maintenance conditions. Any use beyond this is deemed to be improper. for any resulting damage the manufacturer is not liable for such use.

7. Recalibration and duration of use

A factory recalibration should be carried out annually. See the relevant label on the sensor. This recalibration can be carried out quickly and easily by Melectric Systems GmbH. Contact us.

When used within the limits of the intended use and more regularly calibration, the service life of the sensor is more than one year.

8. Structural changes

Unauthorized conversions or changes to the torque measuring system are for safety reasons forbidden and lead to the immediate expiration of warranty claims

9. Assembly and Disassembly

Care must be taken to ensure that the flat surfaces of the flanges are clean when installing the sensor issue. The screws must be tightened crosswise in several stages to the nominal torque. When fastening, no force may be exerted on the housing in the axial direction. The sensor is not designed as a support bearing.

10. Disposal:

For disposal, the device must be returned to Melectric Systems GmbH, Endlhauser Straße 7, 82064 Straßlach.

11. Key Sensor Parameter

- Available Torque Range from 0,1 Nm to 5000 Nm
- Rotational speed measurement up to 8000 rpm
- Accuracy < 0,2% FS
- Protection grade IP54

12. Typical Values

Description	Unit	Value
Linearity including Hysteresis	% FS	0,2 (0,1% Optional)
Repeatability	% FS	0,05
Standard sampling Frequency	Hz	200 Hz
Signal Resolution	Bit	16 bit signal resolution
Drift on Zero Singal by Temperature	%/10K	0,1
Drift on Output Signal by Temperature	%/10K	0,1
Storage Temperature	°C	-20 to 70
Maximum Temperature range	°C	-20 to 70
Maximum rotational speed	rpm	Range 1 Nm to 100 Nm 8000 rpm Range 200 Nm to 5000 Nm 6000 rpm
Power consumption	mA	<150 mA
Power Supply	V	12V/24V
Type	Value	
Load limits	% Mnom	150%
Max. axial load without changing Measurement Limits	% Mnom	150%
Limit Torque for mechanic	% Mnom	200%
Permissible stress under dynamic load	% Mnom	70 (peak – peak)

Any irregular stress (bending moment, transverse, or longitudinal force, exceeding the nominal torque) is up to the specified Limit allowed only as long as none of the other of them can occur. Otherwise, the limit values are to be reduced. If 30% of the bending moment limit and the transverse force limit occur, only 40% of the longitudinal limit force are permissible, whereby the Nominal torque must not be exceeded.

13. Dimension

Sensor Dimension for 0,1 to 3 Nm

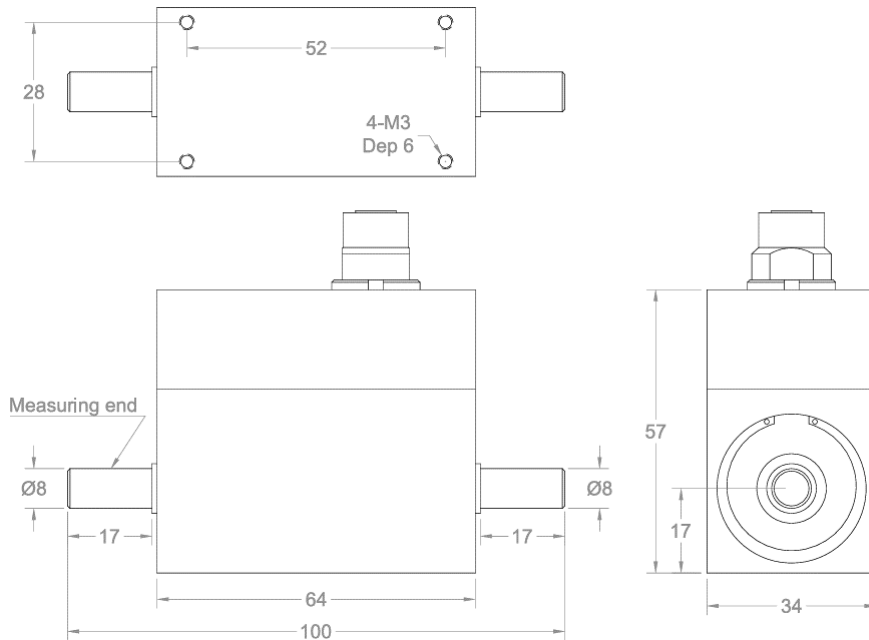

All Units in mm

For customized solutions or dimensions please contact us at:

info@melectric-systems.de

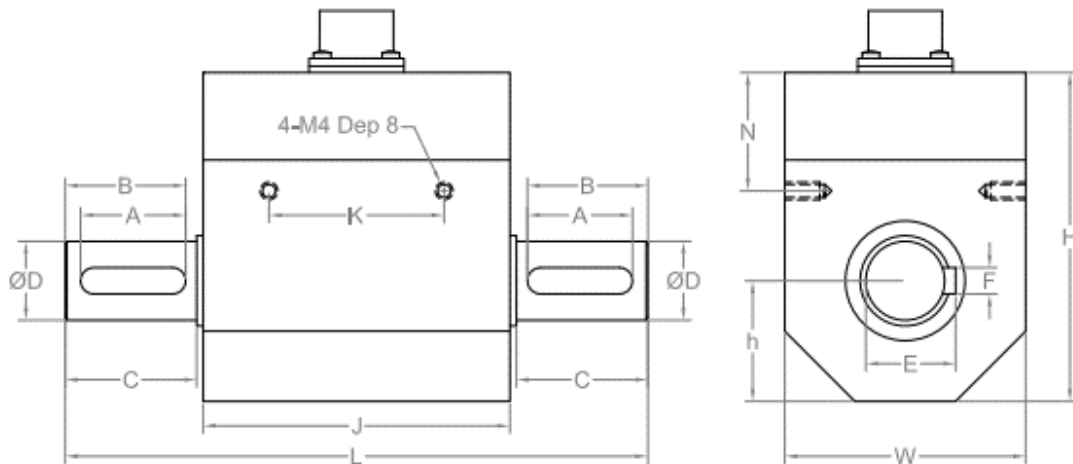

Value	5 Nm to 100 Nm	200 Nm to 500 Nm
A	24	30
B	27,5	33
C	30	35
D	18 +0/-0,05	28 +0/-0,05
E	20,5	31
F	6	8
H	75	85
J	70	70
'h	27,5	32,5
K	40	46
L	133	144
N	27	28
W	55	65

All Units in mm

For customized solutions or dimensions please contact us at:

info@melectric-systems.de

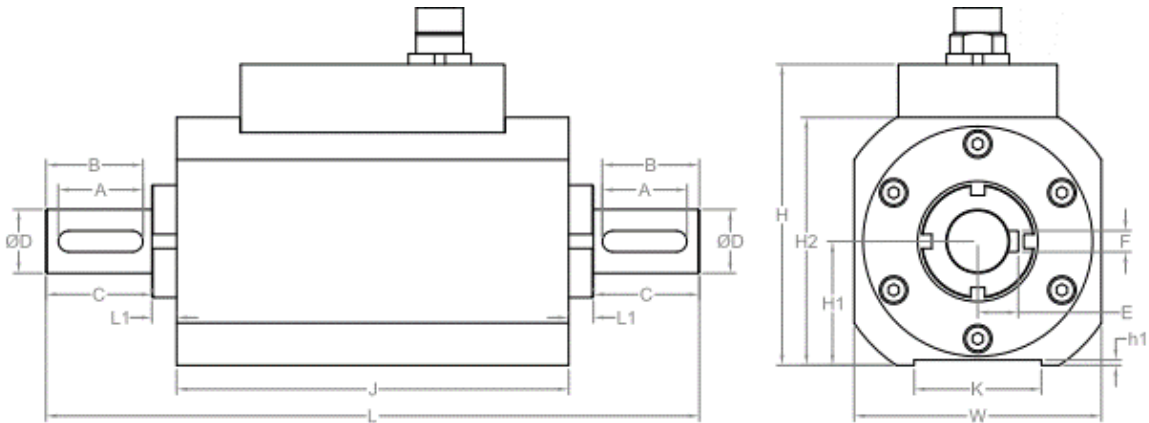

Value	1 / 1.5 / 2 kNm	3kNm and 5kNm
A	60	93
B	65	97
C	70	100
D	45	75
E	4x Keyway 26x14x4	4x Keyway 42x20x4
F		
H	135	170
J	134	414
'h	10	8
K	134	141
L	288	355
W	125	160

All Units in mm

For customized solutions or dimensions please contact us at:

info@melectric-systems.de

14. Accessories

15. Adapter clutches

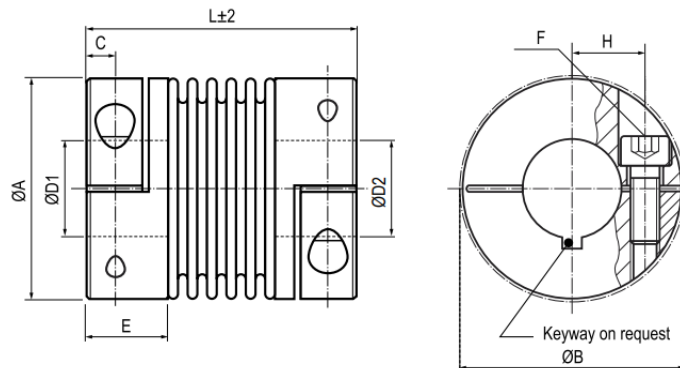

Value	1 Nm to 100 Nm	200 Nm to 500 Nm
A	45 – 82	90 - 122
B	47,4 – 82,9	90,8 – 110
C	5,5 – 9,8	10,8 – 13,3
D1	18	28
D2	10 – 44	16 – 70
E	17,5 - 27	29 – 36
F	M5 – M10	M12
H	17 – 28	31 – 42
L	58 - 89	83 - 111

The specific Dimension will be quoted with the measurement range – please ask your sales representative for more details.

Order Codes

Serie MES – 0,1 Nm to 5000 Nm												
Measurement range												
01	including 3m cable											
02	including 3m cable											
05	including 3m cable											
1	including 3m cable											
2	including 3m cable											
3	including 3m cable											
5	including 3m cable											
10	including 3m cable											
20	including 3m cable											
30	including 3m cable											
50	including 3m cable											
100	including 3m cable											
200	including 3m cable											
300	including 3m cable											
500	including 3m cable											
1000	including 3m cable											
1500	including 3m cable											
2000	including 3m cable											
3000	including 3m cable											
5000	including 3m cable											
	<table border="1"> <thead> <tr> <th>Torque Sensor Output</th> <th>Angle Sensor Output</th> </tr> </thead> <tbody> <tr> <td>1</td> <td>-5V to +5V</td> <td>0- 5 V</td> </tr> <tr> <td>2</td> <td>-10V to +10V</td> <td>0 - 10 V</td> </tr> <tr> <td>3</td> <td>4 to 20 mA</td> <td>4 - 20 mA</td> </tr> </tbody> </table>	Torque Sensor Output	Angle Sensor Output	1	-5V to +5V	0- 5 V	2	-10V to +10V	0 - 10 V	3	4 to 20 mA	4 - 20 mA
Torque Sensor Output	Angle Sensor Output											
1	-5V to +5V	0- 5 V										
2	-10V to +10V	0 - 10 V										
3	4 to 20 mA	4 - 20 mA										
	<table border="1"> <thead> <tr> <th colspan="2">Supply Voltage</th> </tr> </thead> <tbody> <tr> <td>1</td> <td>12 V</td> </tr> <tr> <td>2</td> <td>24 V</td> </tr> </tbody> </table>	Supply Voltage		1	12 V	2	24 V					
Supply Voltage												
1	12 V											
2	24 V											
	X no angle sensor required											
	Z Option 0,1% accuracy											

MES -				
-------	--	--	--	--